



MSW2T-2735-196/-197

Wei Bo Associates HK Limited

S Band High Power Switch Module - SMT

Features:

- Surface Mount S- Band Limiter Module:
 - -196: 9mm x 6mm x 2.5mm – clockwise topology
 - -197: 9mm x 6mm x 2.5mm – counter clockwise topology
- Frequency Range: 2.7 to 3.5 GHz
- High Average Power Handling (CW): +57 dBm
- High Peak Power Handling: +60 dBm
- Low Insertion Loss: 0.4 dB
- Return Loss (Ant-Tx): 16 dB
- Isolation: 37 dB
- RoHS Compliant

Description:

The MSW2T-2735-196/-197 SP2T surface mount High Power PIN Diode switches operates from the S Band frequency range from 2.7 GHz to 3.5 GHz: The MSW2T-2735-196/-197 high power switch leverages high reliability hybrid manufacturing processes which yield both superior RF and thermal characteristics performance when compared to MMIC or Glass Carrier based technologies. The hybrid design approach permits precise PIN Diode selection to optimize RF performance while maintaining competitive cost targets. The small form factor (9mm x 6mm x 2.5mm) offers world class power handling, low insertion loss, and superior isolation performance in a single device. The MSW2T-2735-196/-197 asymmetrical switches are tailored to minimize Transmit to Antenna loss while maximizing Transmit to Receive isolation. The hybrid assembly has been designed with an extremely low thermal resistance of 4.3 °C/W which will reliably permit handling up to 57 dBm CW power and up to 60 dBm peak RF incident power while operating at the $T_{amb} (MAX) = +80^{\circ}C$.

ESD and Moisture Sensitivity Rating

The MSW2T-2735-196/-197 Switch Module carries a Class 1 ESD rating (HBM) and an MSL 1 moisture rating.

Thermal Management Features

The MSW2T-2735-196/-197 has been design to offer superior long term reliability in the customer's application by utilizing ultra-thin Au plating to combat Au embrittlement concerns. Also, a proprietary design methodology minimizes thermal resistance from the PIN Diode junction to base plate (R_{THJ-A}) to the customer's substrate and associated heat sink. This circuit topology coupled with the thermal characteristic of the substrate design enables reliably handling High Input RF Power up to 57 dBm CW and RF Peak Power levels up to 60dBm with the base plate temperature at 80°C.

MSW2T-2735-196/-197 Switch Module Equivalent Circuit

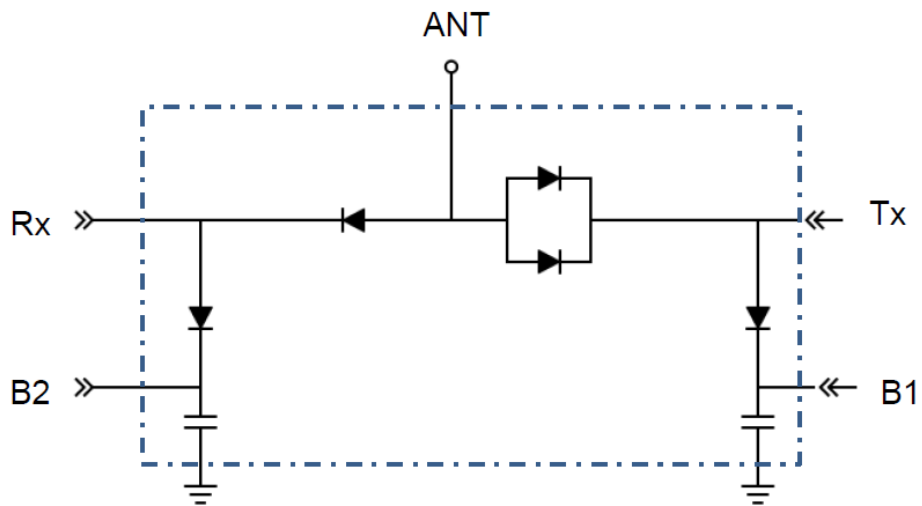

Absolute Maximum Ratings

@ Zo=50Ω, TA= +25°C as measured on the base ground surface of the device.

Parameter	Conditions	Absolute Maximum Value
DC Forward Current @ B1		400 mA
DC Reverse Voltage @ B1		50 V
DC Forward Diode Voltage @ B1 or B2	150 mA	1.2 V
Operating Temperature		-54°C to 80°C
Storage Temperature		-65°C to +150°C
Junction Temperature		+175°C
Assembly Temperature	T = 10 sec	+260°C for 10 sec
Peak Incident Power Handling	500 usec pulse width, 20% duty cycle source and load VSWR = 1.2 : 1 (max); T _{case} = 80°C	57 dBm
Thermal Resistance from Die Junction to Ground Plane Surface on Bottom of Package		4.3 °C/W

Note 1: T_{CASE} is defined as the temperature of the bottom ground surface of the device.

MSW2T-2735-196/197 Electrical Specification – 2.7 to 3.5 GHz

@ Zo=50Ω, TA= +25°C as measured on the base ground surface of the device.

Parameter	Symbol	Test Condition	Min Value	Typ Value	Max Value	Units
Frequency	F		2.7		3.5	GHz
Ant-Tx Insertion Loss	IL (Tx)	Condition 1		0.4	0.5	dB
Ant-Tx Return Loss	RL (Tx)	Condition 1	13	16		dB
Ant-Rx Insertion Loss	IL (Rx)	Condition 2		0.4	0.5	dB
Ant-Rx Return Loss	RL (Rx)	Condition 2	13	16		dB
Ant-Rx Isolation	ISO	Condition 1	35	37		dB
Tx Incident Power	P_{inc} (TxCW)	Condition 1			57	dBm
Tx Incident Power	P_{inc} (TxPeak)	Condition 1, Pulse Width = 10 usec, Duty Cycle = 1%			60	dBm
Rx Incident Power	P_{inc} (RxCW)	Condition 2			47	dBm
Switching Time	t_{sw}	Condition 1, 2, 3, 50% TTL to 90% RF Voltage			700	nsec
Ant-Rx Input Power	P_{inc} (Rx)	Condition 3			47	dBm
Ant-Rx Input Power	P_{inc} (Rx)	Condition 4			50	dBm

MSW2T-2735-196/197 Electrical Specifications - Upper S Band Frequency

@ Zo=50Ω, TA= +25°C as measured on the base ground surface of the device.

Parameter	Symbol	Test Condition	Min Value	Typ Value	Max Value	Units
Frequency	F		2.9		3.5	GHz
Ant-Tx Insertion Loss	IL (Tx)	Condition 1		0.4	0.5	dB
Ant-Tx Return Loss	RL (Tx)	Condition 1	13	16		dB
Ant-Rx Insertion Loss	IL (Rx)	Condition 2		0.4	0.5	dB
Ant-Rx Return Loss	RL (Rx)	Condition 2	13	16		dB
Ant-Rx Isolation	ISO	Condition 1	35	37		dB
Tx Incident Power	P_{inc} (TxCW)	Condition 1			57	dBm
Tx Incident Power	P_{inc} (TxPeak)	Condition 1, Pulse Width = 10 usec, Duty Cycle = 1%			60	dBm
Rx Incident Power	P_{inc} (RxCW)	Condition 2			47	dBm
Switching Time	t_{sw}	Condition 1, 2, 3, 50% TTL to 90% RF Voltage			700	nsec
Ant-Rx Input Power	P_{inc} (Rx)	Condition 3			47	dBm
Ant-Rx Input Power	P_{inc} (Rx)	Condition 4			50	dBm

Conditions:

1. Tx-ANT High Power Transmit State:
 - a. Input signal: 500W @ 500 us PW & 20% DC.
 - b. Source/Load VSWR \leq 1.2 : 1
 - c. DC Bias: 5V, 400mA at ANT port and 0.0V, -400mA at Tx, B2 port, and 45V, 100mA at Rx port, 50V, 0mA at B1 port.
2. ANT-Rx Small Signal Receive State:
 - a. Input signal: -10 dBm
 - b. Source/Load VSWR \leq 1.2 : 1
 - c. DC Bias: 5V, 100mA at ANT port and 0.0V, -100mA at Rx, B1 port and 45V, 100mA at Tx port, 45V, 0mA at B2 port
3. ANT-Rx Large Signal Receiver Protection State
 - a. Input signal: 47 dBm CW
 - b. Source/Load VSWR \leq 1.2 : 1
 - c. DC Bias: 5V, 100mA at ANT port and 0.0V, -100mA at Rx, B1 port and 45V, 100mA at Tx port, 45V, 0mA at B2 port
4. ANT-Rx Moderate Power Receiver Protection State
 - a. Source/Load VSWR = 1.2 : 1
 - b. Input signals: unsynchronized, 50 dBm CW
 - c. DC Bias; OFF

MSW2T-2735-196/-197 Operating Truth Table:

Tx Mode	Rx Mode	Ant Bias	Tx Bias	B1 Bias	Rx Bias	B2 Bias
Low Insertion Loss	High Impedance Isolation	5.0 V @ 400 mA (nom)	0.0 V @ -400 mA (nom)	45 V @ 0 mA (nom)	45 V @ 100 mA (nom)	0.0 V @ -100 mA (nom)
High Impedance Isolation	Low Insertion Loss	5.0 V @ 100 mA (nom)	45 V @ 100 mA (nom)	0.0 V @ -100 mA (nom)	0.0 V @ -100 mA (nom)	45 V @ 0 mA (nom)

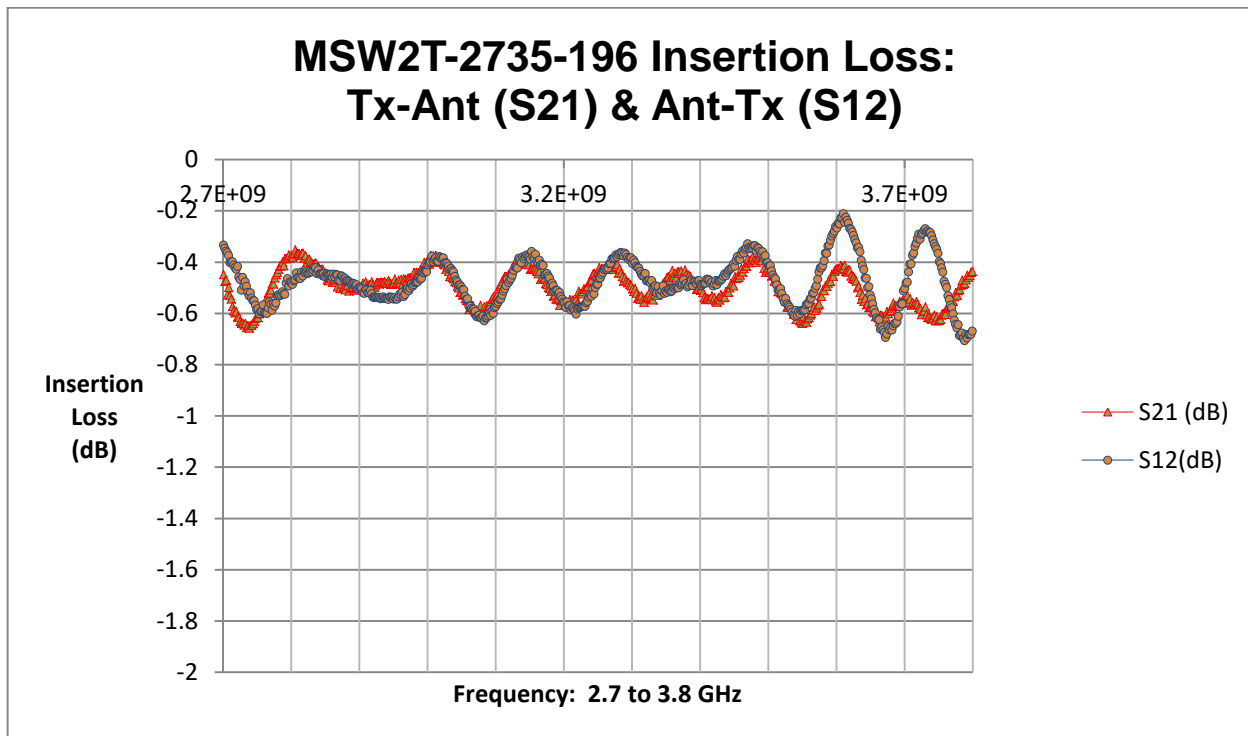

MSW2T-2735-196 Return Loss: Rx-Ant(S22) & Ant-Rx(S11)

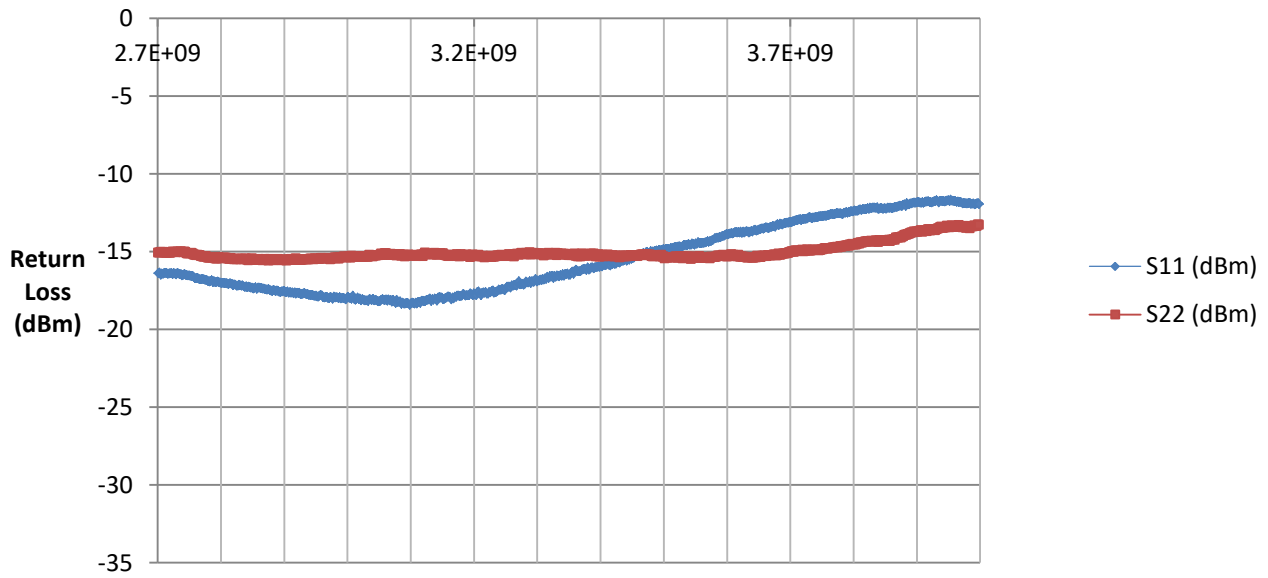

MSW2T-2735-196 Isolation vs Frequency

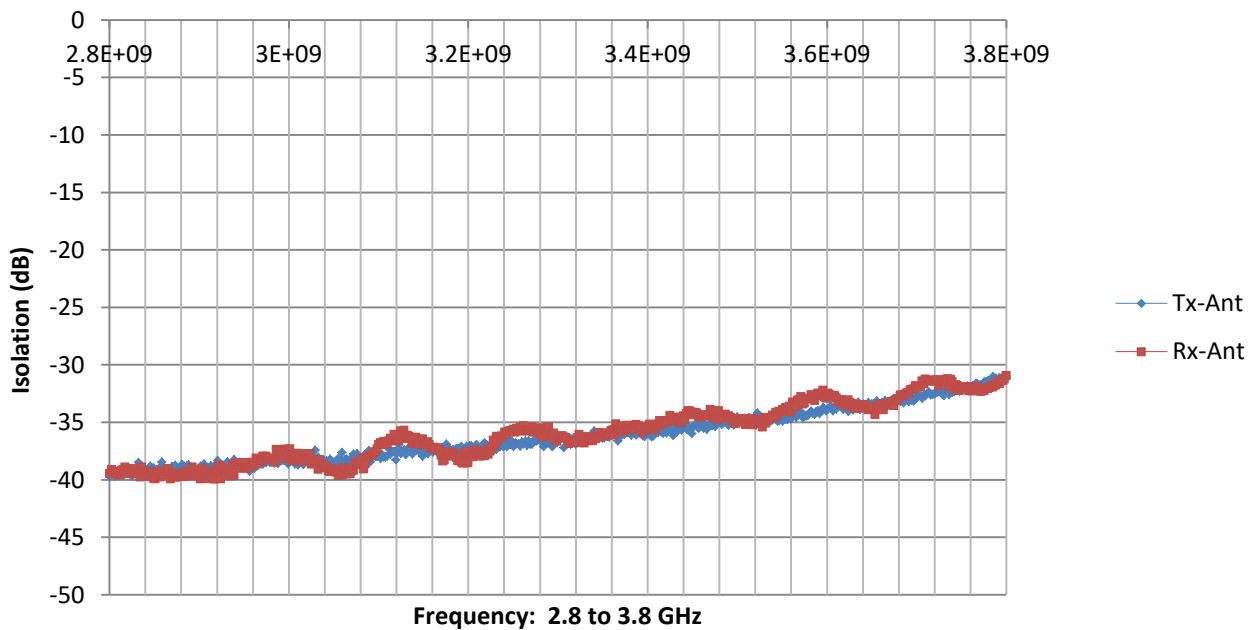

Assembly Instructions

The MSW2T-2735-196/-197 may be attached to the printed circuit card using solder reflow procedures using either RoHS or Sn63/ Pb37 type solders per the Table and Temperature Profile Graph shown below:

Profile Parameter	Sn-Pb Assembly Technique	RoHS Assembly Technique
Average ramp-up rate (T_L to T_P)	3°C/sec (max)	3°C/sec (max)
Preheat		
Temp Min (T_{smin})	100°C	100°C
Temp Max (T_{smax})	150°C	150°C
Time (min to max) (t_s)	60 – 120 sec	60 – 120 sec
T_{smax} to T_L Ramp up Rate		3°C/sec (max)
Peak Temp (T_P)	225°C +0°C / -5°C	245°C +0°C / -5°C
Time within 5°C of Actual Peak Temp (T_P)	10 to 30 sec	20 to 40 sec
Time Maintained Above: Temp (T_L) Time (t_L)	183°C 60 to 150 sec	217°C 60 to 150 sec
Ramp Down Rate	6°C/sec (max)	6°C/sec (max)
Time 25°C to T_P	6 minutes (max)	8 minutes (max)

Solder Re-Flow Time-Temperature Profile

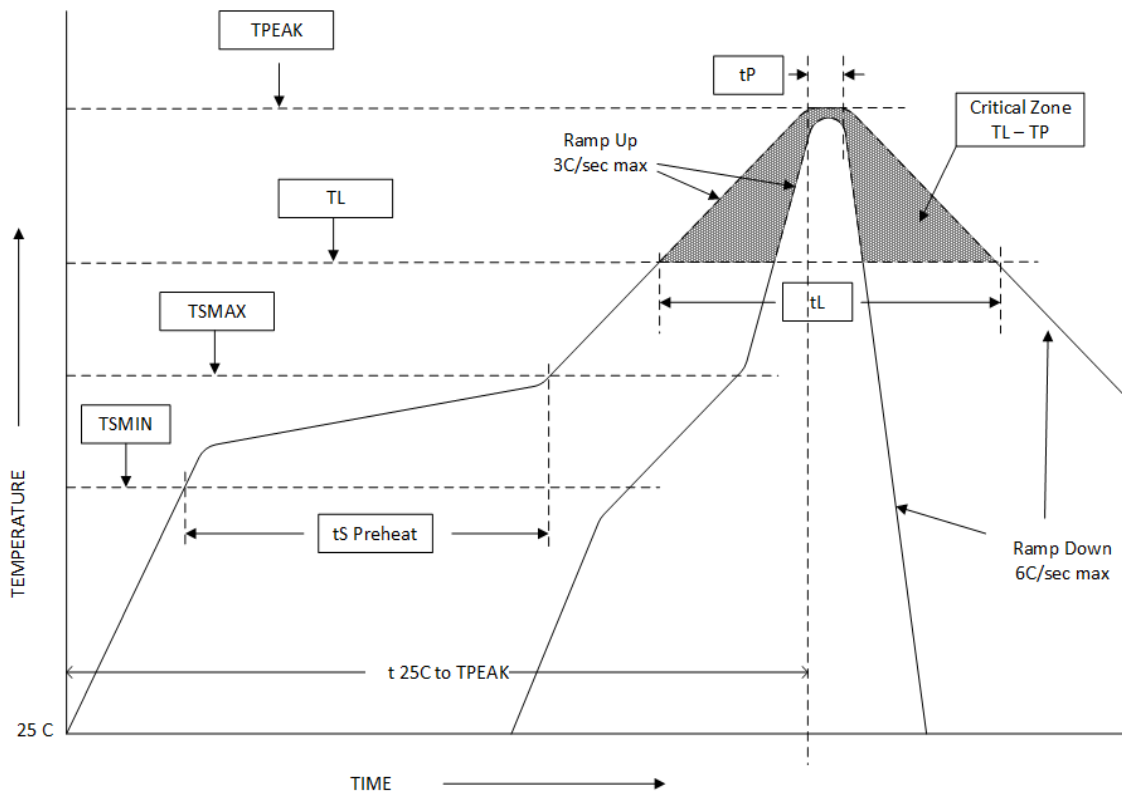

MSW2T-2735-196 Switch Module (Clockwise) Package Outline Drawing

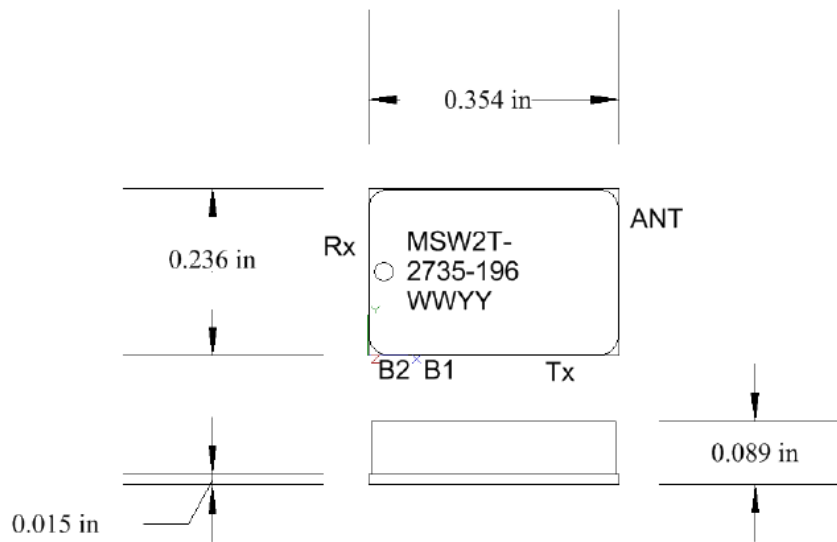

MSW2T-2735-196 (clockwise) Top View of Bottom Surface

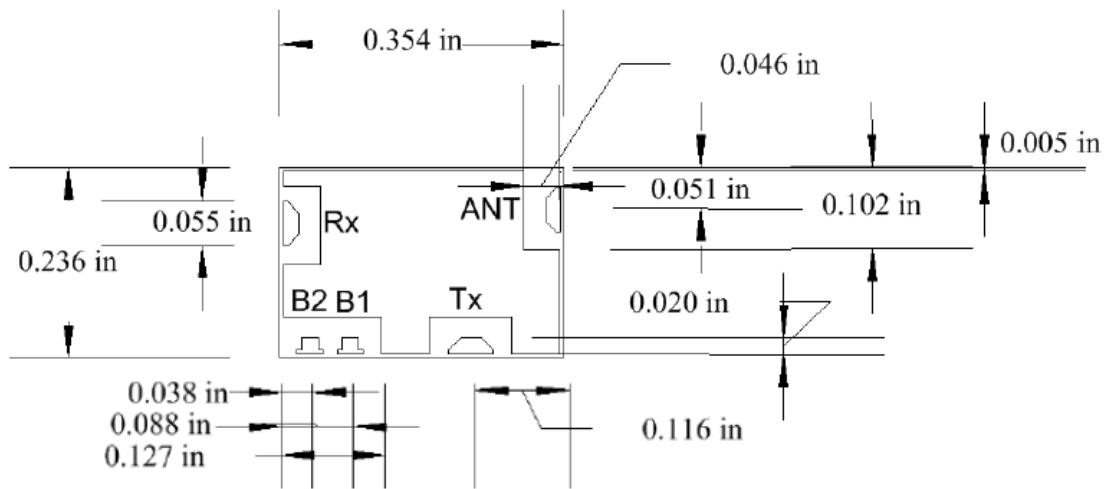

Notes:

- 1) Metalized area on backside is the RF, DC and Thermal ground. In user's end application this surface temperature must be managed to meet the power handling requirements.
- 2) Back side metallization 10 – 20 Micro Inches (typ) Au termination plating to combat Au embrittlement (Au plated over Cu).
- 3) RF Cover: White Ceramic
- 4) Substrate Material: 15 mils Aluminum Nitride (AlN)

Recommended RF Circuit Solder Footprint for the MSW2T-2735-196

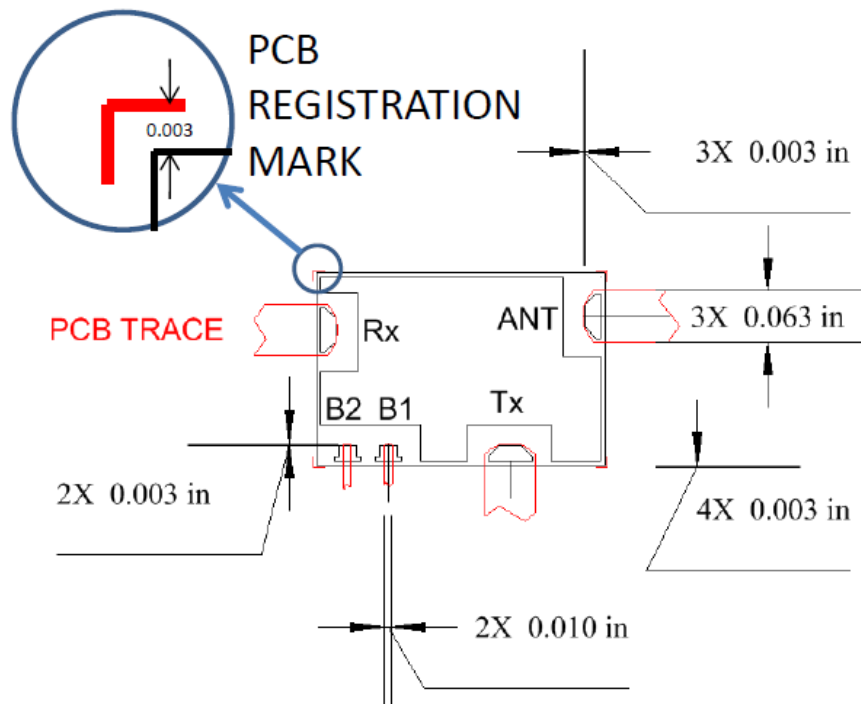

Notes:

- 1) Recommended PCB material is Rogers R6002, 25 mils thick (RF Input and Output trace width needs to be adjusted from the recommended footprint.)
- 2) Hatched area is RF, DC and Thermal Ground. Vias should be solid Cu filled and Au plated for optimal heat transfer from backside of Limiter Module through circuit vias to thermal ground.

MSW2T-2735-197 Switch Module Package (counter clockwise) Outline

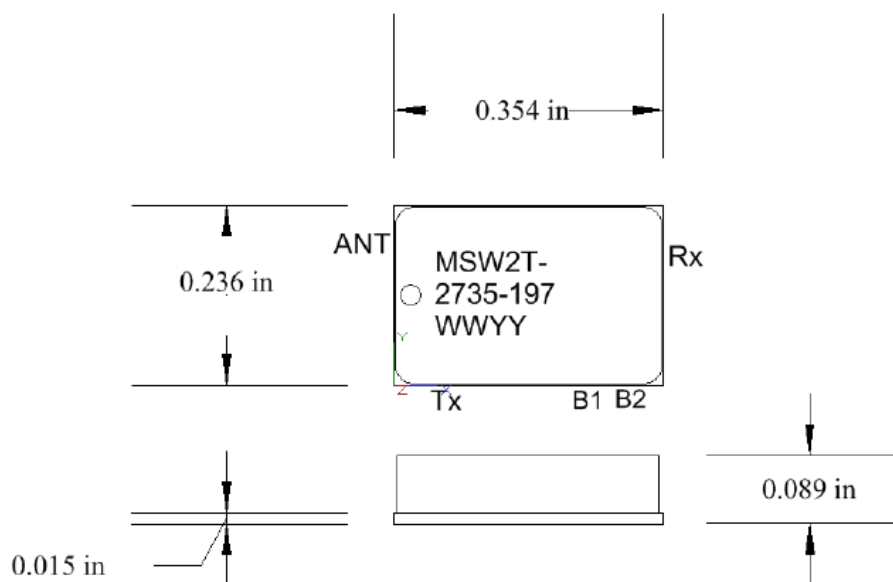

MSW2T-2735-197 (counter clockwise) Top View of Bottom Surface

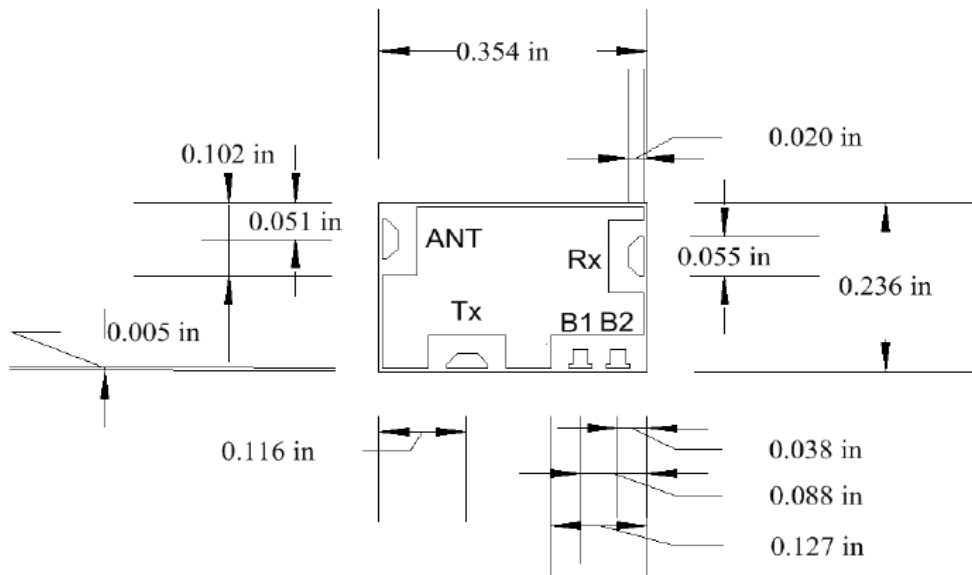

Notes:

- 1) Metalized area on backside is the RF, DC and Thermal ground. In user's end application this surface temperature must be managed to meet the power handling requirements.
- 2) Back side metallization 10 – 20 Micro Inches (typ) Au termination plating to combat Au embrittlement (Au plated over Cu).
- 3) RF Cover: White Ceramic
- 4) Substrate Material: 15 mils Aluminum Nitride (AlN)

Recommended RF Circuit Solder Footprint for the MSW2T-2735-197

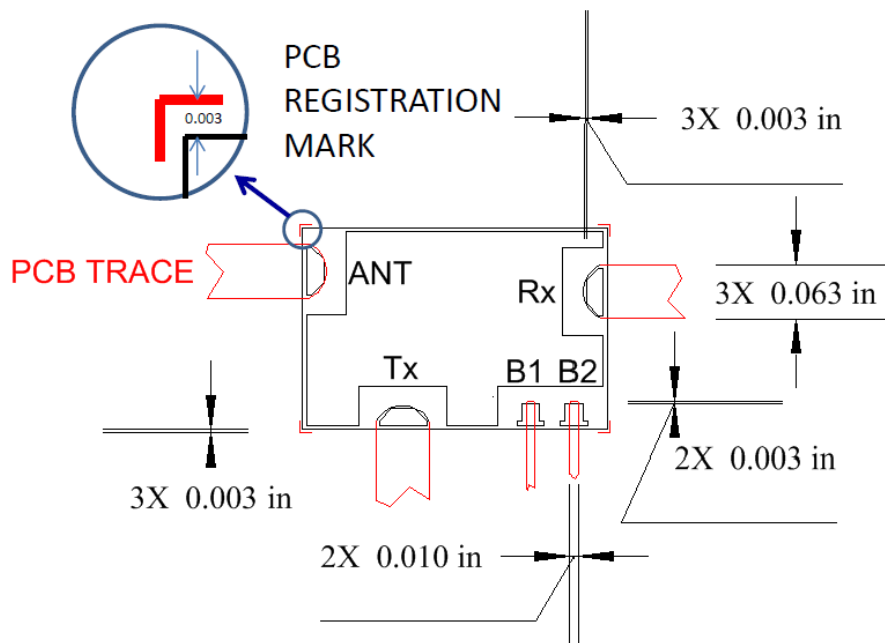

Thermal Design Considerations:

The design of the MSW2T-2735-196/-197 Switch Module permits the maximum efficiency in thermal management of the PIN Diodes while maintaining extremely high reliability. Optimum switch performance and reliability of the device can be achieved by the maintaining the base ground surface temperature of less than 80°C.

There must be a minimal thermal and electrical resistance between the limiter bottom surface and ground. Adequate thermal management is required to maintain a T_{JC} at less than +175°C and thereby avoid adversely affecting the semiconductor reliability. Special care must be taken to assure that minimal voiding occurs in the solder connection beneath the device.

Part Number Ordering Detail:

The MSW2T-2735-196/-197 switch modules are available in in the following shipping format:

Part Number	Description	Packaging
MSW2T-2735-196	S-Band Switch Module – 9mm x 6mm - CW	Gel-Pack
MSW2T-2735-197	S-Band Switch Module – 9mm x 6mm - CCW	Gel-Pack